



File E14721

Vol 11

Auth. Page 1

Issued: 2006-08-09

Revised: 2012-03-23

FOLLOW-UP SERVICE PROCEDURE
(TYPE R)

COMPONENT - FUSEHOLDERS, CARTRIDGE FUSE
(IZLT2)

Manufacturer: SEE ADDENDUM FOR MANUFACTURER LOCATIONS

Applicant: 104923 (Party Site)
LITTELFUSE INC
(491993-001) SUITE 500
8755 W HIGGINS RD
CHICAGO IL 60631

Recognized Company: 104923 (Party Site)
SAME AS APPLICANT
(491993-001)

This Follow-Up Service Procedure authorizes the above Manufacturer(s) to use the marking specified by UL LLC, or any authorized licensee of UL LLC, including the UL Contracting Party, only on products when constructed, tested and found to be in compliance with the requirements of this Follow-Up Service Procedure and in accordance with the terms of the applicable service agreement with UL Contracting Party and any applicable Service Terms. The UL Contracting Party for Follow-Up Services is listed on addendum to this Follow-Up Service Procedure ("UL Contracting Party"). UL Contracting Party and UL LLC are referred to jointly herein as "UL."

UL further defines responsibilities, duties and requirements for both Manufacturers and UL representatives in the document titled, "UL Mark Surveillance Requirements" that can be located at the following web-site: <http://www.ul.com/fus> and in the document titled "UL and Subscriber Responsibilities" that can be located at the following website: <http://www.ul.com/responsibilities>. Manufacturers without Internet access may obtain the current version of these documents from their local UL customer service representative or UL field representative. For assistance, or to obtain a paper copy of these documents or the applicable Service Terms, please contact UL's Customer Service at <http://www.ul.com/global/eng/pages/corporate/contactus>, select a location and enter your request, or call the number listed for that location.

The Applicant, the specified Manufacturer(s) and any Recognized Company in this Follow-Up Service Procedure must agree to receive Follow-Up Services from UL Contracting Party. If your applicable agreement is a Global Services Agreement ("GSA") with an effective date of January 1, 2012 or later and this Follow-Up Service Procedure is issued on or after that effective date, the Applicant, the specified Manufacturer(s) and any Recognized Company will be bound to a Service Agreement for Follow-Up Services upon the earliest by any Subscriber of use of the prescribed UL Mark, acceptance of the factory inspection, or payment of the Follow-Up Service fees which will incorporate such GSA, this Follow-Up Service Procedure and the Follow-Up Service Terms which can be accessed by clicking here: <http://www.ul.com/contracts/Terms-After-12-31-2011>. In all other events, Follow-Up Services will be governed by and incorporate the terms of your applicable service agreement and this Follow-Up Service Procedure.

It is the responsibility of the Recognized Company to make sure that only the products meeting the aforementioned requirements bear the authorized Marks of UL LLC, or any authorized licensee of UL LLC.

This Follow-Up Service Procedure contains information for the use of the above Manufacturer(s) and representatives of UL and is not to be used for any other purpose. It is provided to the Manufacturer with the understanding that it will be returned upon request and is not to be copied in whole or in part.

This Follow-Up Service Procedure, and any subsequent revisions, is the property of UL and is not transferable. This Follow-Up Service Procedure contains confidential information for use only by the above named Manufacturer(s) and representatives of UL and is not to be used for any other purpose. It is provided to the Subscribers with the understanding that it is not to be copied, either wholly or in part unless specifically allowed, and that it will be returned to UL, upon request.

Capitalized terms used but not defined herein have the meanings set forth in the GSA and the applicable Service Terms or any other applicable UL service agreement.

UL shall not incur any obligation or liability for any loss, expense or damages, including incidental, consequential or punitive damages arising out of or in connection with the use or reliance upon this Follow-Up Service Procedure to anyone other than the above Manufacturer(s) as provided in the agreement between UL LLC or an authorized licensee of UL LLC, including UL Contracting Party, and the Manufacturer(s).

UL LLC has signed below solely in its capacity as the accredited entity to indicate that this Follow-Up Service Procedure is in compliance with the accreditation requirements.

William R. Carney
Director
North American Certification Program

LOCATION

(479717-001) 102306 (Party Site)
ZHEJIANG MINGRONG ELECTRICAL
PROTECTION CO LTD
WEI 11TH RD
ECONOMIC DEVELOPING ZONE
YUEQING,
ZHEJIANG 325600 CHINA

Factory ID:
UL Contracting Party for above site is: UL AG

ML FILE NO. E35113

Issued: 2008-04-15

MULTIPLE RECOGNITION
of
FUSEHOLDERS, CARTRIDGE FUSE - COMPONENT
(IZLT2)
for

[504921-002] MARATHON SPECIAL PRODUCTS CORP

Basically Recognized for:

[491993-001] LITTELFUSE INC (NBK)

Basically Recognized products covered by Procedure and/or Reports under File No. E14721, Volume 11

Products Covered	Report Date	Basic Applicant's (Supplier's) Product Designation	Multiple Listee's Product Designations
	2006-07-28	LPSM CH LPSM-ID-CH	6SM30A-B 6SM30AI-B

MARKING: Same as that described in Follow-Up Service Procedure and/or Report except for Multiple Listee's name, ML Tradename, when applicable, and product designation.

UL INSPECTION CENTER HANGZHOU - 325

ML FILE NO. E39328

Issued: 2009-11-19

MULTIPLE RECOGNITION
of
FUSEHOLDERS, CARTRIDGE FUSE - COMPONENT
(IZLT2)
for

[532762-001] SCHURTER AG

Basically Recognized for:

[491993-001] LITTELFUSE INC (NBK)

Basically Recognized products covered by Procedure and/or Reports under File No. E14721, Volume 11

Products Covered	Report Date	Basic Applicant's (Supplier's) Product Designation	Multiple Listee's Product Designation
	2006-07-28	LPHV	FSO

MARKING: Same as that described in Follow-Up Service Procedure and/or Report except for Multiple Listee's name, ML Tradename, when applicable, and product designation.

Recognized Component Marking Data Page (RCMDP)

(FILE IMMEDIATELY AFTER AUTHORIZATION PAGE)

RECOGNIZED COMPONENT MARKING

Products Recognized under UL's Component Recognition Service are identified by marking elements consisting of:

1. The Recognized Company's identification specified in this document.
2. A catalog, model or other applicable product designation specified in the descriptive sections of this document.
3. The UL Recognized Component Mark shown below is optional unless required elsewhere in the Procedure.

Only those components, which actually bear the Marking, should be considered as being covered under the Recognition Program. The UL Listing or Classification Mark is not authorized for use on or in connection with Recognized Components.

Recognized Component Mark



Minimum size of the Recognized Component Mark is not specified as long as it is legible. Minimum height of the registered symbol ® shall be 3/64 inch but may be omitted if it is out of proportion to the Recognized Component Mark or not legible to the naked eye.

The manufacturer may reproduce the Mark electronically. Any decision regarding the acceptability of the manufacturer's Mark reproduction will be made at the Reviewing Office.

INDEX

MODELS	SECTION
Fuseholder, Cartridge Fuse - Series. LPSM CH, LPSM-ID CH, LPHV, LPSM000 followed by 1Z, 2Z, 3Z or 4Z, may be followed by XID	1
Transferred	2
Fuseholder, Cartridge Fuse - Series. LPSM-QC, LPSM-QC ID	3

File E14721
Project 09CA30118

September 2, 2009

REPORT

on

COMPONENT - Fuseholders, Cartridge Fuse

Littelfuse Inc
Des Plaines, IL

Recognized Company: Littelfuse Inc

Copyright © 2009 Underwriters Laboratories Inc.

Underwriters Laboratories Inc. authorizes the above named company to reproduce this Report provided it is in its entirety.

Underwriters Laboratories Inc. authorizes the above named company to reproduce the latest pages of that portion of this Report consisting of this Cover Page through Page 3.

DESCRIPTION

PRODUCT COVERED:

USR - Component Fuseholder, Cartridge Fuse - Series LPSM-QC and LPSM-QC ID. See table for part number details. These fuseholders are offered in a 1, 2, 3, and 4 pole configuration. The Box Label Part No. designation is as follows based on the pole configuration:

Box Label Part No.	Catalog No.	No. of Poles
LPSM0001ZQC	LPSM0001QC	1
LPSM0001ZQCID	LPSM001QCID	1
LPSM0002ZQC	LPSM002QC	2
LPSM0002ZQCID	LPSM002QCID	2
LPSM0003ZQC	LPSM003QC	3
LPSM0003ZQCID	LPSM003QCID	3
LPSM0004ZQC	LPSM004QC	4
LPSM0004ZQCID	LPSM004QCID	4

Each individual pole of the fuseholder is marked with the base part no. LPSM-QC or LPSM-QC ID. The box label indicates the number of poles of the fuseholder.

RATINGS:

Cat. No.	For Use With Fuse Size	Ampere Ratings	Voltage Rating	Withstand Rating, kA
LPSM-QC	10 x 38 mm	30	600 V ac	200
LPSM-QC ID			600 V dc	20

GENERAL CHARACTER AND USE:

1. These are 1-pole fuseholders that can be ganged together and are intended for use with 10 x 38 mm cartridge fuses, rated a maximum of 30 A, 600 V. They are for use on circuits with a maximum available short circuit current of 200,000 A rms symmetrical or 20,000 A dc.
2. These fuseholders are designed such that the fuses can be completely separated from the line and load fuse clips by means of a pullout fuse carrier.
3. These fuseholders also have optional open fuse indication.
4. These fuseholders are intended **to** be DIN rail mounted.
5. These fuseholders are not intended to make or break under load.
6. USR **indicates** investigation to UL 4248-1, the General Requirements for Fuseholders, **1st Edition, dated February 28, 2007.**

MARKINGS:

A fuseholder shall be plainly and legibly marked to indicate:

The Recognized Company, trademark, or other descriptive marking by which the organization responsible for the product may be identified.

The catalog number or the equivalent.

Electrical ratings may also be marked on the fuseholder.

TECHNICAL CONSIDERATIONS (NOT FOR FIELD REPRESENTATIVE'S USE):

Fuses covered by this Report are intended for supplementary overcurrent protection where branch circuit or equivalent applications are not involved.

Use - For use only in equipment where the acceptability of the combination has been determined by Underwriters Laboratories Inc.

Conditions of Acceptability -

1. When used in equipment, electrical spacings between live parts of opposite polarity and between live parts and grounded metal should be in accordance with the requirements of the equipment in which the fuseholder is installed.

2. These fuseholders have been investigated for use in a circuit capable of delivering the level of current tabulated, when used with fuses having the tabulated let-through characteristics.

Fuseholder	Maximum Circuit		Let-Through Values	
	Current	Voltage	I_p	I^2t
LPSM-QC/LPSM-QC ID	200 kA	600 V ac	13.3 kA	32.0 kA ² s

3. The suitability of these devices for use with aluminum conductors should be determined in the end-use application.

4. These fuseholders are intended for use with 10 by 38 mm supplemental fuses. A temperature test shall be conducted in the end-use application.

5. These fuseholders are designed with a rotating fuse carrier. It is not intended to make and/or break under load.

6. These polymeric materials used in this fuseholder are rated 140°C at 1.5 mm thickness. This limit shall not be exceeded in the end use.

CONSTRUCTION DETAILS:

The fuseholders covered in this Report shall be constructed in accordance with the following description.

SERIES LPSM QC & LPSM-QC ID - ILL 1

General - These figures show views of assembled and disassembled units. The relationship of the internal components to the overall construction are displayed. These fuseholders may be provided in a 1, 2, 3, and 4 pole configuration.

1. Assembled Fuseholder - Each individual pole measures 80 mm long, 18 mm wide, 60 mm. The overall dimensions are shown in ILL. 1.

2. Case - R/C (QMFZ2) DSM Engineering Plastics B V, Material Designation K222-KGV4, 1.5 mm minimum thick.

Alternate - Same as above except, DSM Engineering Plastics B V, Material Designation TV4 260S.

Alternate - Same as above except, DSM Engineering Plastics B V, Material Designation K-FKGS6.

3. Cover - R/C (QMFZ2) DSM Engineering Plastics B V, Material Designation K222-KGV4, 1.5 mm minimum thick.

Alternate - Same as above except, DSM Engineering Plastics B V, Material Designation TV4 260S.

Alternate - Same as above except, DSM Engineering Plastics B V, Material Designation K-FKGS6.

4. Fuse Carrier/Toggle - R/C (QMFZ2) DSM Engineering Plastics B V, Material Designation K222-KGV4, approximately 46 by 34 by 17.5 mm overall, 1.5 mm thick.

Alternate - Same as above except, DSM Engineering Plastics B V, Material Designation K-FKGS6.

5. Fuseclip/Terminal Bus - Plated copper alloy, 0.6 mm thick, approx. 29.3 by 23.3 by 11.4 mm overall. Terminal end is 6.6 mm wide with integral tabs in middle and 90 deg bend at end to position and secure wire terminal. Fuseclip is formed to accommodate 10 mm dia fuse ferrule. Fuseclip is provided with "U" shaped spring steel clip, 1.6 mm dia, to reinforce contact with fuse ferrule.

*

6. Quick Connect - Constructed of silver plated copper, see ILL. 2 for dimensional details.
7. Din Rail Lock - Captive plastic snap lock, with integral molded "spring", for mechanical securement to DIN rail.
8. Indicator Assembly - Consists of:
 - a). Housing of R/C(QMFZ2), polyamide (PA66), A9705, by Nanjing Lihan Chemical Co Ltd.
 - b). Spring steel contacts and terminals 2.6 mm wide, 0.15 mm thick.
 - c). LED across the terminals. Assembly is secured in toggle by plastic "plug" that is snap-fit into slots in side of toggle.

and Report

REVISION		
REV	DATE	DESCRIPTION
1	6/15/09	UL quote

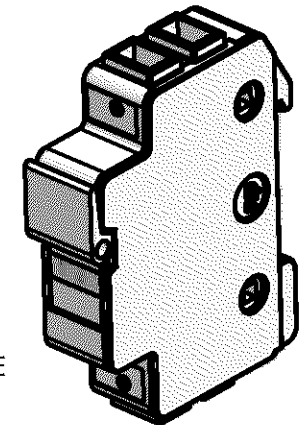
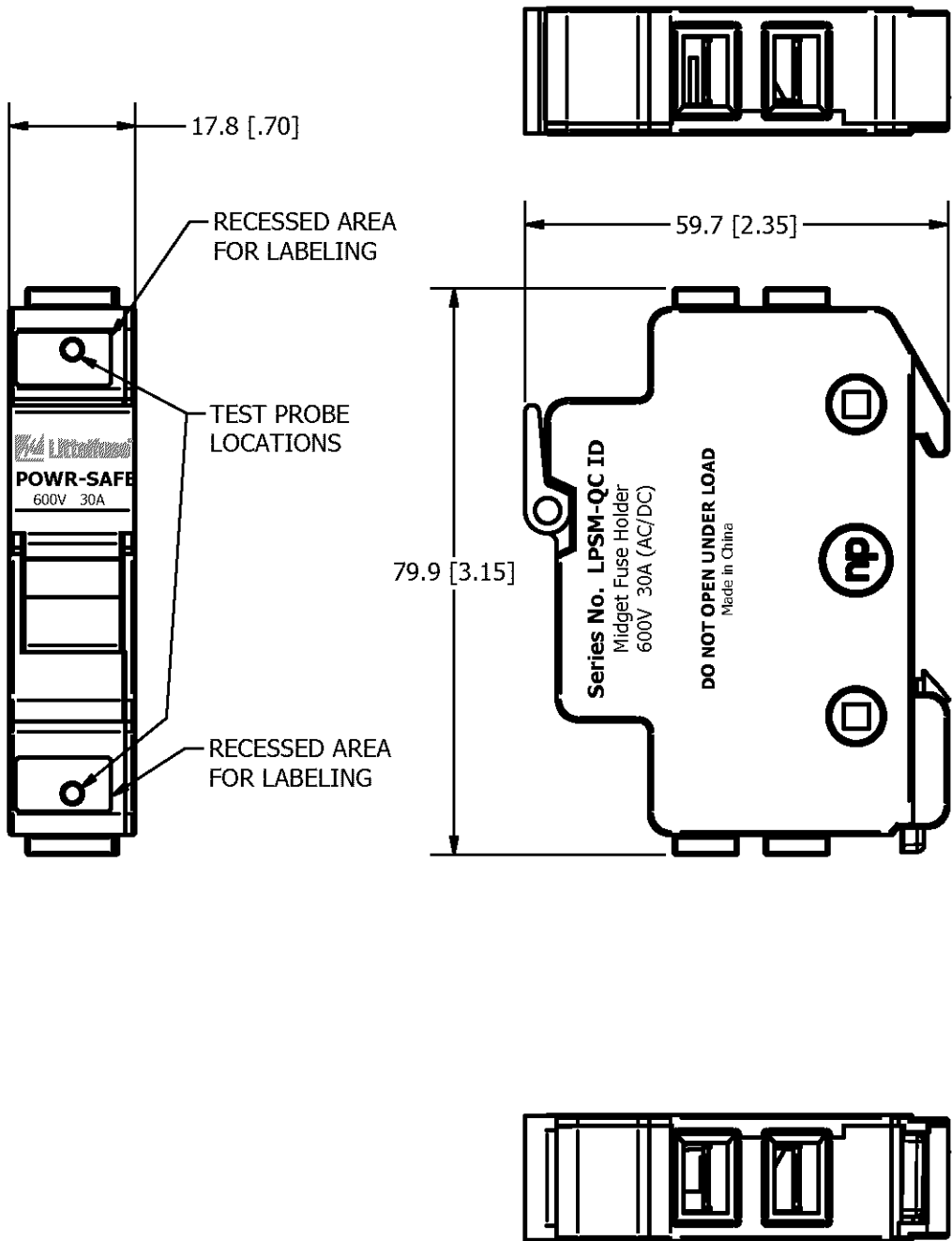

NOTES:

1. PRINTING DETAILS SUBJECT TO CHANGE
2. APPROVED MATERIALS:
 HOUSING: K222-KGV4
 CARRIER: K222-KGV4
 FUSE CLIP: SILVER PLATED COPPER
 REINFORCING CLIP: ZINC CHROMATE PLATED STEEL

●	DENOTES CRITICAL CHARACTERISTICS.
CPK	DENOTES CPK DIMENSIONS, -MINIMUM CPK VALUE
ST	DENOTES A CHARACTERISTIC THAT PROVIDES AN INDICATION OF PROCESS PERFORMANCE. PROCEDURE FOR MEASUREMENT AND TRACKING TO BE DEFINED IN LITTELFUSE INSPECTION INSTRUCTIONS.
CP	DENOTES CP DIMENSIONS, -MINIMUM CP VALUE MUST BE WITHIN THE DIMENSIONAL LIMITATIONS SHOWN ON DRAWING AND INITIALLY LOCATED TO ALLOW FOR MAXIMUM TOOL LIFE.

A

MATL SPEC		FINISH	
DRW NCS	DATE 5/22/2009	SCALE NTS	FINISH GOOD WT GRAMS/PIECE

UNLESS OTHERWISE SPECIFIED, DIMENSIONS ARE IN MILLIMETERS, DIMENSIONS IN BRACKETS [] ARE INCHES DIMENSIONING AND DO NOT INCLUDE PLATING. TOLERANCING TO BE INTERPRETED IN ACCORDANCE WITH ANSI Y14.5M-1994

3RD ANGLE PROJECTION	TOLERANCE UNLESS OTHERWISE SPECIFIED
	ONE PLACE DEC ± .25 [.01] FRACTION ±
	TWO PLACE DEC ± .100 [.004] ANGULAR ±1°

TITLE	LPSM Quick Connect
-------	--------------------

Littelfuse DES PLAINES, ILLINOIS 60016	REVISION 1	DRWG NO. LPSM-QC-ID Outline	SHEET 1 OF 1
--	---------------	--------------------------------	--------------

NOTES
1. MAX .25 [.010] CUTOFF FLASH ALLOWABLE AND IT MUST NOT BE WIDER OR THICKER THAN THE LEAD

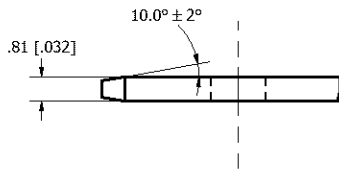

DETAIL B
SCALE 8 : 1

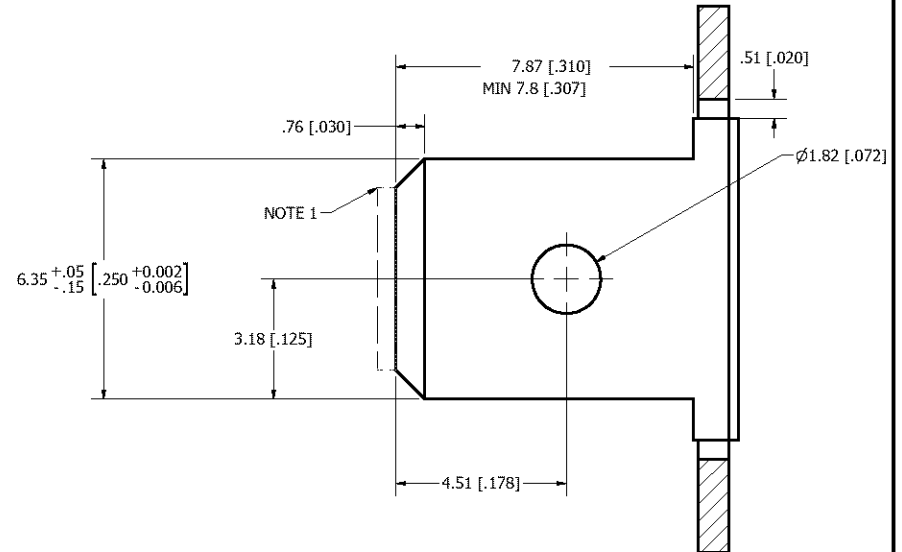
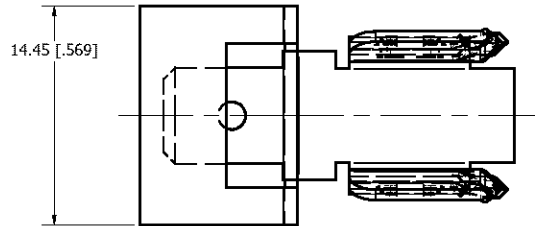
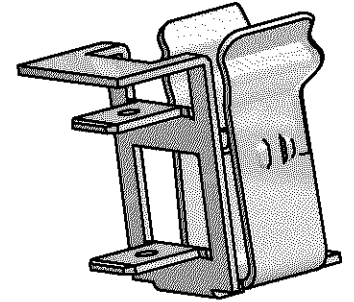

SECTION A-A
SCALE 10 : 1

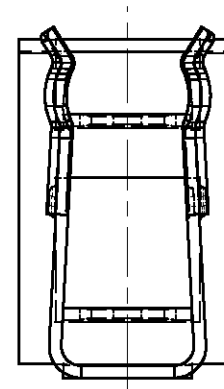
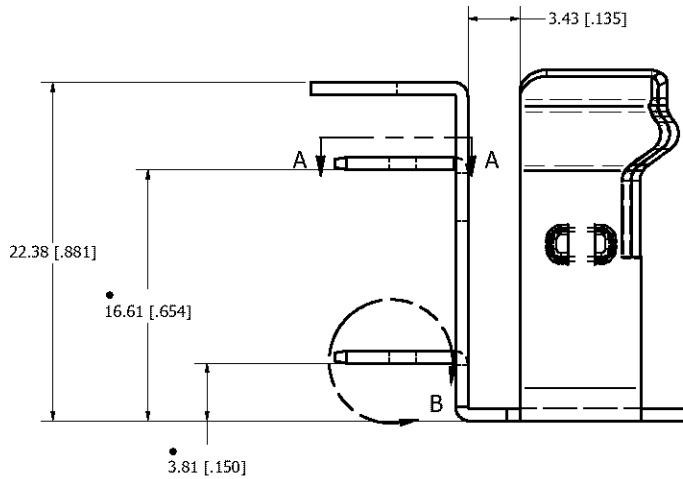

●	DENOTES CRITICAL CHARACTERISTICS.		
CPK	DENOTES CPK DIMENSIONS, -MINIMUM CPK VALUE		
(ST)	DENOTES A CHARACTERISTIC THAT PROVIDES AN INDICATION OF PROCESS PERFORMANCE. PROCEDURE FOR MEASUREMENT AND TRACKING TO BE DEFINED IN LITTELFUSE INSPECTION INSTRUCTIONS		
CP	DENOTES CP DIMENSIONS, -MINIMUM CP VALUE MUST BE WITHIN THE DIMENSIONAL LIMITATIONS SHOWN ON DRAWING AND INITIALLY LOCATED TO ALLOW FOR MAXIMUM TOOL LIFE		
MATERIAL SPEC SILVER PLATED COPPER		FINISH	
DRW NCS	DATE 5/28/2009	SCALE NTS	FINISH GOOD WT GRAMS/PIECE
UNLESS OTHERWISE SPECIFIED, DIMENSIONS ARE IN MILLIMETERS, DIMENSIONS IN BRACKETS [] ARE INCHES DIMENSIONING AND DO NOT INCLUDE PLATING. TOLERANCING TO BE INTERPRETED IN ACCORDANCE WITH ANSI Y14.5M-1994			
3RD ANGLE PROJECTION	TOLERANCE UNLESS OTHERWISE SPECIFIED ONE PLACE DEC ±.25 [.01] FRACTION ± TWO PLACE DEC ±.10 [.004] ANGULAR ±1°		
TITLE LPSM with Quick Connect			
Littelfuse DES PLAINES, ILLINOIS 60016		REVISION 1	DRWG NO. UL clip print